

A young German company offers innovative grippers and services for highly flexible handling by robots in production or logistics

Summary

Profile type

Business Offer

Company's country

Germany

POD reference

BODE20220316014

Profile status

PUBLISHED

Type of partnership

Commercial agreement

Targeted countries

Term of validity

16 Mar 2022

16 Mar 2023

Last update

16 Mar 2022

General Information

Short summary

A German spin-off of a local university specializes in the development and sale of highly adaptable grippers for robots in production and logistic applications. Therefore the SME offers individual industrial grippers which enable industrial producers and logistics companies to manufacture and transport customized products cost-effectively and automatically. The SME is looking for technical, commercial with tech. assistance and research cooperation agreements to further develop the product.

Full description

The German company offers industrial grippers with an innovative system. These grippers can be used across various industries and applications and are aimed to integrated automation, motion and drive solutions. The solution addresses industrial producers and logistics companies who want to produce or transport their customer-specific products cost-effectively, efficiently and automatically.

The gripper consists essentially of a base frame with a connection for a volume flow, an air-permeable cushion with a granulate filling and a flexible outer skin. The functional principle of the overall system is based on gripping by vacuum and form closure, shape adaptation by flow of the granulate and solidification of the gripper cushion by the volume flow. This functional principle enables three different operating states of the gripper cushion, which can be changed almost seamlessly. The gripper cushion can be freely deformable or completely rigid. In between, there is a state in which the cushion can be deformed, but stores the current shape. Using an extensive process, the company manufactures individual grippers for each customer.

The company is interested in commercial agreements with technical assistance and technology agreements with companies interested to sell and distribute the product and to integrate the grippers into new or existing robot cells. Additionally the company is searching for research partners for the further development of the system.

Advantages and innovations

The patented solution offers the following advantages:

- shape flexibility: Due to the granule-filled cushion, the grippers can automatically adapt different objects
- simple commissioning: the technology facilitates the programming of automated processes
- resource efficiency: by using the grippers, companies save energy, storage and maintenance costs.
- customer-specific
- very versatile

Technical specification or expertise sought

Stage of development

Already on the market

IPR Status

IPR granted

Sustainable Development goals

- **Goal 9: Industry, Innovation and Infrastructure**

Partner Sought

Expected role of the partner

The German company is targeting for commercial partnerships with technical assistance and research/technology cooperation.

- looking for distribution partners or wholesalers in the field of integrated automation, motion & drive solutions and for system integrators for commercial agreements with technical assistance to integrate the system in existing robot cells
- for the further development of the grippers the company is looking for research cooperation.

Type of partnership

Commercial agreement

Type and size of the partner

- **SME <=10**
- **SME 11-49**
- **SME 50 - 249**
- **Big company**

Dissemination

Technology keywords

- **02003002 - Manufacturing plants networks**
- **02003001 - Process automation**

Targeted countries

Market keywords

- **08002003 - Process control equipment and systems**
- **08002007 - Other industrial automation**
- **08002004 - Robotics**
- **08006001 - Process control and logistics**

Sector groups involved

Media

Images



[tile](#)



[split](#)

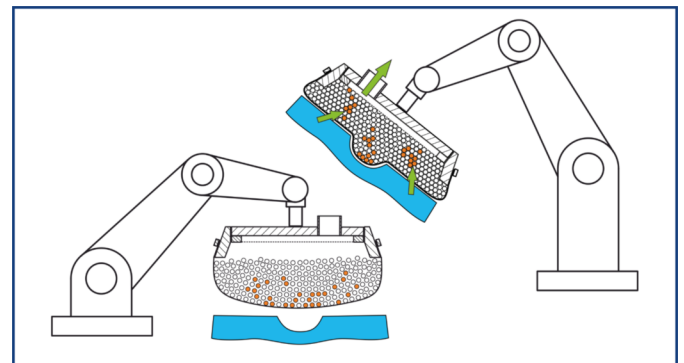

[fm1](#)



[vehicle parts](#)

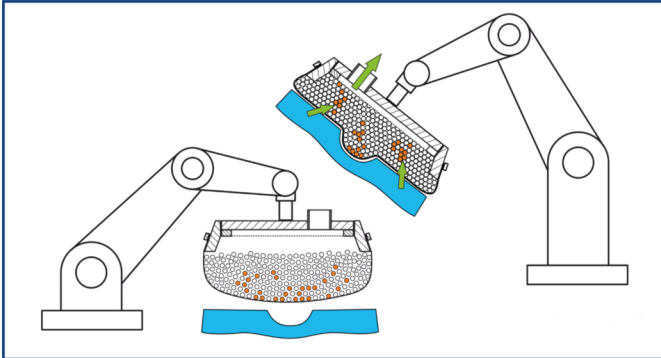

[fm2](#)